

# SHAFT

# SHAFT

The NB shaft can be used in a wide range of applications as a mechanical component from straight shaft to spindle shaft. NB's expertise in machining and heat-treatment turns into manufacturing spindle shaft, roll shaft, and general machinery shaft for rotational motion. NB's high accuracy technology answers various shaft machining requirements.

## ADVANTAGES

### Advanced Machining Technology

NB performs a wide variety of highly accurate machining processes to provide custom shafting from relatively simple machining, such as tapping and shaft stepping to the more demanding high-speed rotating shafts and spindles. NB can also answer the special grinding and bore machining requirements.

### Excellent Wear Resistance

Most commonly used materials are high-carbon chromium bearing steel (SUJ2) and martensite stainless steel (SUS440C or equivalent). NB's advanced heat-treatment technology gives these materials an excellent wear resistance by quenching and tempering to achieve a uniform hardened layer in the circumferential and axial directions. The cross-sectional picture below shows the hardened layer-depth of the NB shaft.

Hardened Layer  
(cross section)



### Surface Roughness

Precision grinding results in a surface roughness of less than 0.4 Ra.

### Wide Selection of Shaft Types

- SN type, SNS type, SNT type,
- SNB, SNSB type (Center-lined tapped shaft)
- SNW, SNWS type (Inch shaft)
- SNW-PD, SNWS-PD type (Inch, pre-drilled shaft)
- Spindle shaft, roll shaft

### Special Requirements

Based on the customer drawings and specifications NB will answer the customer requirements in material (SCM, SKS etc.), heat-treatment, surface treatment, etc.

### Shaft Supporter and Shaft Support Rail

These components ease the shaft installation and help save the design/assembling time. (refer to page F-14)

### FIT Series

This series is a set of NB slide bush and NB shaft. By precise shaft-grinding, FIT series achieves the best-fit clearance adjustment for a smooth, high accuracy linear motion. (refer to page F-24)

## TYPES

SN/SNS/SNT type (NB Shaft)  
SNW/SNWS type (Inch Shaft)

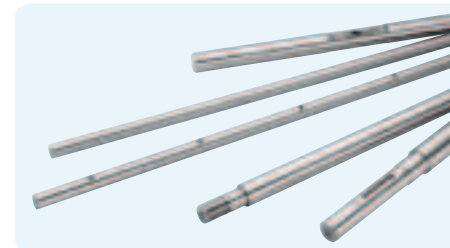

SNB/SNSB type (NB Center-lined Tapped Shaft)  
SNW-PD/SNWS-PD type (Inch Shaft, Pre-drilled Shaft)

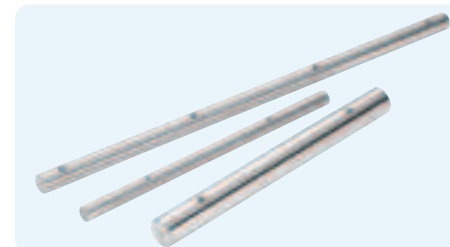

### Shaft Supporter and Shaft Support Rail

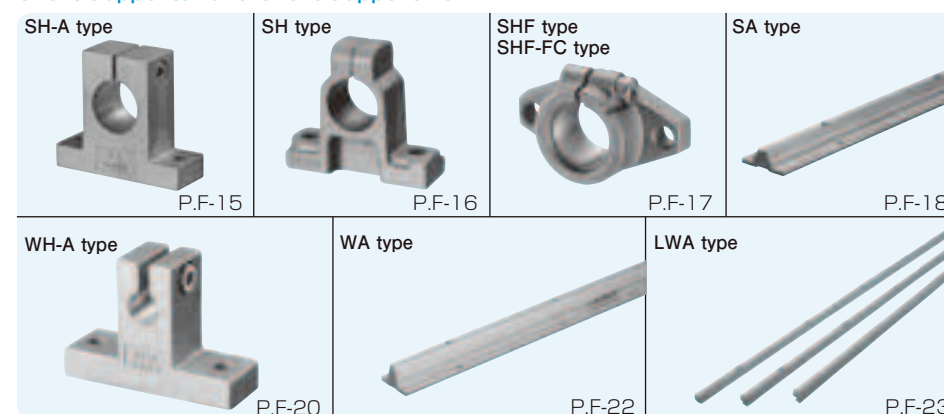

### Special Specifications



NB shaft is a high-precision shaft that can be used with slide bush or any other bearings. A wide range of machining is provided for customer drawings and requirements.

Table F-1 Specifications

type	SN type	SNS type	SNT type
material	SUJ2	equivalent to SUS440C	SUJ2 (hollow shaft)
outer diameter tolerance	g6 or to be specified		
hardness	60HRC or more	56HRC or more	60HRC or more
surface roughness	less than 0.4Ra		
page	page F-6	page F-7	page F-8

Center-lined tapped shafts are standardized series for easy selection that can be used with the SA shaft support rails. (refer to page F-18)

Table F-2 Specifications

type	SNB type	SNSB type
material	SUJ2	equivalent to SUS440C
outer diameter tolerance	g6 or to be specified	
hardness	60HRC or more	56HRC or more
surface roughness	less than 0.4Ra	
page	page F-9	

The SNW and SNWS types are inch dimensional shafts with the same specifications as SN/SNS type (refer to page F-10,11). SNW-PD and SNWS-PD types are standardized series that can be used with the WA shaft support rails. (refer to page F-12,13,22)

### CALCULATION OF DEFLECTION AND DEFLECTION ANGLE

The following formulas are used to obtain the deflection and its angle of the shaft. Typical conditions are listed in Table F-3.

Table F-3 Formulas for Calculating Deflection and Deflection Angle

support method	specification	formula for deflection	formula for deflection angle
1 support   support		$\delta_{max} = \frac{P\ell^3}{48EI} = P\ell^3C$	$i_1 = 0$ $i_2 = \frac{P\ell^2}{16EI} = 3P\ell^2C$
2 fixed   fixed		$\delta_{max} = \frac{P\ell^3}{192EI} = \frac{1}{4}P\ell^3C$	$i_1 = 0$ $i_2 = 0$
3 support   support		$\delta_{max} = \frac{5p\ell^4}{384EI} = \frac{5}{8}p\ell^4C$	$i_2 = \frac{p\ell^3}{24EI} = 2p\ell^3C$
4 fixed   fixed		$\delta_{max} = \frac{p\ell^4}{384EI} = \frac{1}{8}p\ell^4C$	$i_2 = 0$
5 support   support		$\delta_1 = \frac{Pa^3}{6EI} \left( 2 + \frac{3b}{a} \right) = 8Pa^3 \left( 2 + \frac{3b}{a} \right) C$ $\delta_{max} = \frac{Pa^3}{24EI} \left( \frac{3\ell^2}{a^2} - 4 \right) = 2Pa^3 \left( \frac{3\ell^2}{a^2} - 4 \right) C$	$i_1 = \frac{Pab}{2EI} = 24PabC$ $i_2 = \frac{Pa(a+b)}{2EI} = 24Pa(a+b)C$
6 fixed   fixed		$\delta_1 = \frac{Pa^3}{6EI} \left( 2 - \frac{3a}{\ell} \right) = 8Pa^3 \left( 2 - \frac{3a}{\ell} \right) C$ $\delta_{max} = \frac{Pa^3}{24EI} \left( 2 + \frac{3b}{a} \right) = 2Pa^3 \left( 2 + \frac{3b}{a} \right) C$	$i_1 = \frac{Pa^2b}{2EI\ell} = \frac{24Pa^2bC}{\ell}$ $i_2 = 0$
7 fixed   free		$\delta_{max} = \frac{P\ell^3}{3EI} = 16P\ell^3C$	$i_1 = \frac{P\ell^2}{2EI} = 24P\ell^2C$ $i_2 = 0$
8 fixed   free		$\delta_{max} = \frac{p\ell^4}{8EI} = 6p\ell^4C$	$i_1 = \frac{p\ell^3}{6EI} = 8p\ell^3C$ $i_2 = 0$
9 support   support		$\delta_{max} = \frac{\sqrt{3}Mo\ell^2}{216EI} = \frac{2\sqrt{3}}{9}Mo\ell^2C$	$i_1 = \frac{Mo\ell}{12EI} = 4Mo\ell C$ $i_2 = \frac{Mo\ell}{24EI} = 2Mo\ell C$
10 fixed   fixed		$\delta_{max} = \frac{Mo\ell^2}{216EI} = \frac{2}{9}Mo\ell^2C$	$i_1 = \frac{Mo\ell}{16EI} = 3Mo\ell C$ $i_2 = 0$

$\delta_1$ : deflection at the concentrated load point (mm)  $\delta_{max}$ : maximum deflection (mm)  $i_1$ : deflection angle at the concentrated load point (rad)  
 $i_2$ : deflection angle at the support point (rad)  $Mo$ : moment (N·mm)  $P$ : concentrated load (N)  
 $p$ : uniformly distributed load (N/mm)  $a, b$ : concentrated load point distance (mm)  $\ell$ : span (mm)  $I$ : moment of inertia of area (mm<sup>4</sup>)  
 $E$ : modulus of longitudinal elasticity (SUJ2)  $2.06 \times 10^5$  (N/mm<sup>2</sup>) (SUS)  $2.0 \times 10^5$  (N/mm<sup>2</sup>)  $C$ :  $1/48EI$  (1/N·mm<sup>2</sup>)

The moment of inertia of area (I) is obtained using the following formulas:

- For solid shaft
- For hollow shaft

$$I = \frac{\pi D^4}{64}$$

$$I = \frac{\pi}{64} (D^4 - d^4)$$

$I$ : moment of inertia of area (mm<sup>4</sup>)  
 $D$ : outer diameter (mm)  $d$ : inner diameter (mm)

The values of the moment of inertia of area and C (=1/48 EI) for NB shafts are listed in Table F-4 and F-5.

### Calculation Examples

1. Calculating the maximum deflection of a 30mm shaft with a 500mm span when a concentrated load of 980 N is applied at the mid-point of the shaft ... (neglecting the shaft weight)

① In case the support method is support-support:  
 From the given conditions,  $P = 980$  N,  $\ell = 500$ mm  
 From Table F-4, C for an outer diameter of 30 mm,  $C = 2.54 \times 10^{-12}$  (N·mm<sup>2</sup>).  
 Substituting these values into the corresponding formula (No. 1) in Table F-3,  
 $\delta_{max} = P\ell^3C = 0.31$  (mm)

② In case the support method is fixed-fixed:  
 Substituting the values into the corresponding formula (No. 2) given in Table F-3,  
 $\delta_{max} = \frac{1}{4}P\ell^3C = 0.08$  (mm)

2. Calculating the maximum deflection of a 60mm shaft with an inner diameter of 32 mm and a 2,000 mm span by its own weight ...

From Table F-5, C for an outer diameter of 60 mm,  $C = 1.73 \times 10^{-13}$  (N·mm<sup>2</sup>)  
 The mass per unit length of a shaft with an outer diameter of 60 mm and an inner diameter of 32 mm is 15.9kg/m. Therefore, a uniformly distributed load of 0.156 N/mm is applied. Substituting these values into the formula (No. 3) given in Table F-3.  
 $\delta_{max} = \frac{5}{8}p\ell^4C = 0.27$  (mm)

Table F-4 Solid Shaft

outer diameter D (mm)	moment of inertia of area I (mm <sup>4</sup> )	C=1/48EI (1/N·mm <sup>2</sup> )
3	3.98	$2.54 \times 10^{-8}$
4	$1.26 \times 10$	$8.03 \times 10^{-9}$
5	$3.07 \times 10$	$3.29 \times 10^{-9}$
6	$6.36 \times 10$	$1.59 \times 10^{-9}$
8	$2.01 \times 10^2$	$5.03 \times 10^{-10}$
10	$4.91 \times 10^2$	$2.06 \times 10^{-10}$
12	$1.02 \times 10^3$	$9.91 \times 10^{-11}$
13	$1.40 \times 10^3$	$7.22 \times 10^{-11}$
15	$2.49 \times 10^3$	$4.06 \times 10^{-11}$
16	$3.22 \times 10^3$	$3.14 \times 10^{-11}$
20	$7.85 \times 10^3$	$1.29 \times 10^{-11}$
25	$1.92 \times 10^4$	$5.27 \times 10^{-12}$
30	$3.98 \times 10^4$	$2.54 \times 10^{-12}$
35	$7.37 \times 10^4$	$1.37 \times 10^{-12}$
40	$1.26 \times 10^5$	$8.03 \times 10^{-13}$
50	$3.07 \times 10^5$	$3.29 \times 10^{-13}$
60	$6.36 \times 10^5$	$1.59 \times 10^{-13}$
80	$2.01 \times 10^6$	$5.03 \times 10^{-14}$
100	$4.91 \times 10^6$	$2.06 \times 10^{-14}$
120	$1.02 \times 10^7$	$9.91 \times 10^{-15}$
150	$2.49 \times 10^7$	$4.06 \times 10^{-15}$

Table F-5 Hollow Shaft

outer diameter D (mm)	inner diameter d (mm)	moment of inertia of area I (mm <sup>4</sup> )	C=1/48EI (1/N·mm <sup>2</sup> )
6	2	$6.28 \times 10$	$1.61 \times 10^{-9}$
8	3	$1.97 \times 10^2$	$5.13 \times 10^{-10}$
10	4	$4.78 \times 10^2$	$2.11 \times 10^{-10}$
12	5	$9.87 \times 10^2$	$1.02 \times 10^{-10}$
13	6	$1.34 \times 10^3$	$7.55 \times 10^{-11}$
16	8	$3.02 \times 10^3$	$3.36 \times 10^{-11}$
20	10	$7.36 \times 10^3$	$1.37 \times 10^{-11}$
25	15	$1.67 \times 10^4$	$6.06 \times 10^{-12}$
30	16	$3.65 \times 10^4$	$2.77 \times 10^{-12}$
35	19	$6.73 \times 10^4$	$1.50 \times 10^{-12}$
40	20	$1.18 \times 10^5$	$8.57 \times 10^{-13}$
50	26	$2.84 \times 10^5$	$3.56 \times 10^{-13}$
60	32	$5.85 \times 10^5$	$1.73 \times 10^{-13}$
80	48	$1.75 \times 10^6$	$5.78 \times 10^{-14}$
100	60	$4.27 \times 10^6$	$2.37 \times 10^{-14}$

# SN TYPE

– NB Shaft –

## part number structure

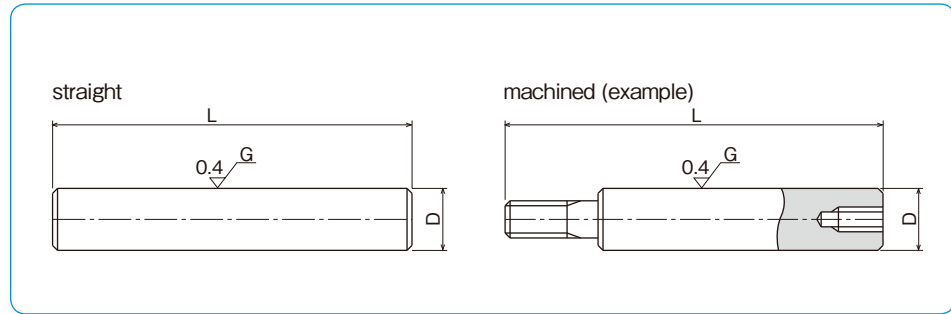
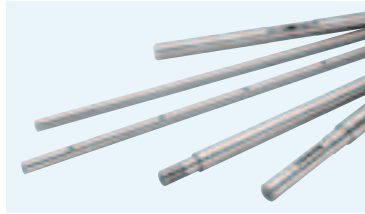
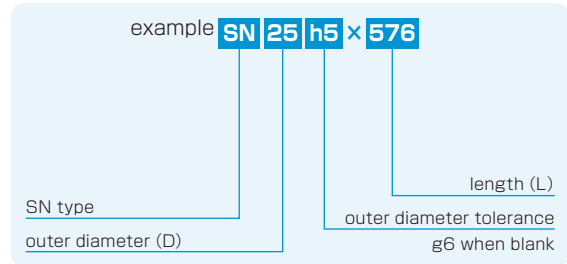

part number	outer diameter D		length L		mass Kg/m
	mm	tolerance g6 μm	mm	mm	
SN 3	3	-2/-8	50	400	0.06
SN 4	4	-4	100	500	0.10
SN 5	5	-12	100	700	0.16
SN 6	6	-5	100	1000	0.23
SN 8	8	-14	200	1500	0.40
SN 10	10	-5	200	2000	0.62
SN 12	12	-17	200	3000	0.89
SN 13	13	-6	200	3000	1.04
SN 15	15	-17	300	4000	1.39
SN 16	16	-17	300	4000	1.58
SN 20	20	-7	300	5000	2.47
SN 25	25	-20	300	6000	3.85
SN 30	30	-20	300	6000	5.55
SN 35	35	-9	400	6000	7.55
SN 40	40	-25	400	6000	9.87
SN 50	50	-10	500	6000	15.4
SN 60	60	-29	600	6000	22.2
SN 80	80	-12	800	6000	39.5
SN100	100	-34	1000	6000	61.7
SN120	120	-14/-39	1500	4500	88.8
SN150	150	-14/-39	1500	4500	139

material: high-carbon chromium bearing steel (SUJ2) hardness: 60HRC (HV697) or more  
Tolerances other than g6 are available upon request.

# SNS TYPE

– NB Stainless Steel Shaft –

## part number structure

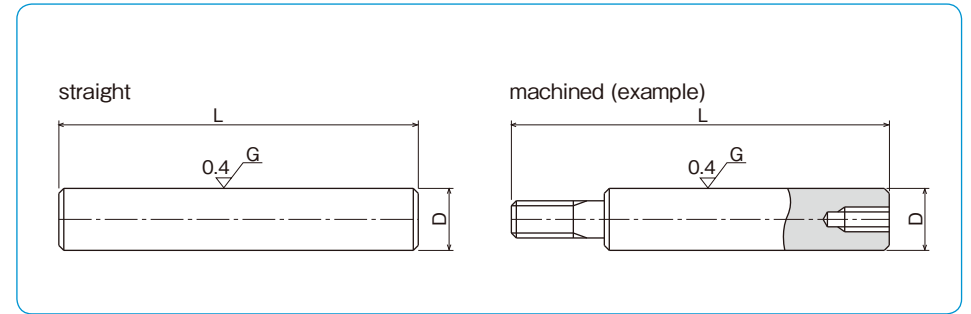
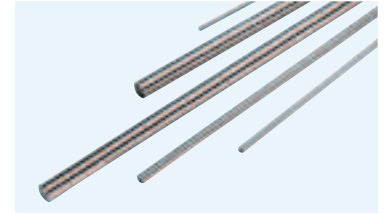
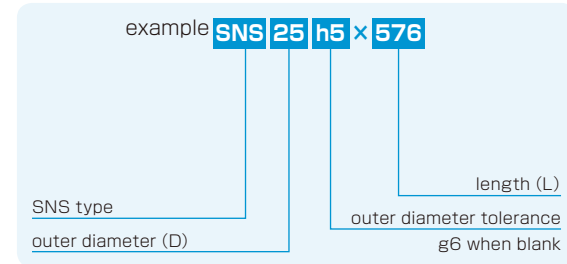

part number	outer diameter D		length L		mass Kg/m
	mm	tolerance g6 μm	mm	mm	
SNS 3	3	-2/-8	50	300	0.06
SNS 4	4	-4	100	400	0.10
SNS 5	5	-12	100	500	0.16
SNS 6	6	-5	100	600	0.22
SNS 8	8	-14	200	1000	0.39
SNS 10	10	-5	200	1500	0.61
SNS 12	12	-6	200	2500	0.88
SNS 13	13	-17	200	3000	1.03
SNS 16	16	-7	300	4000	1.56
SNS 20	20	-20	300	5000	2.43
SNS 25	25	-7	300	6000	3.80
SNS 30	30	-20	300	6000	5.48
SNS 35	35	-9	400	6000	7.46
SNS 40	40	-25	400	6000	9.75
SNS 50	50	-10	500	6000	15.2
SNS 60	60	-29	600	6000	21.9
SNS 80	80	-12	800	6000	39.0
SNS100	100	-34	1000	6000	60.9

material: martensite stainless steel (equivalent to SUS440C)

hardness: 56HRC (HV613) or more

The maximum length of hardening is up to 4500mm for shafts with diameter over 80mm.

Tolerances other than g6 are available upon request.

# SNT TYPE

– NB Hollow Shaft –

## part number structure

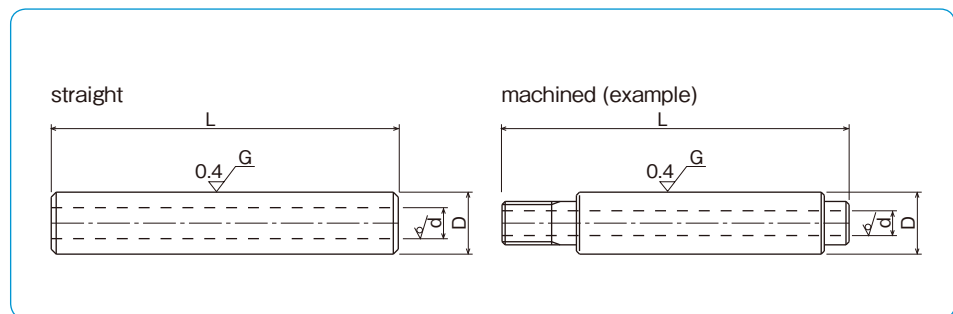
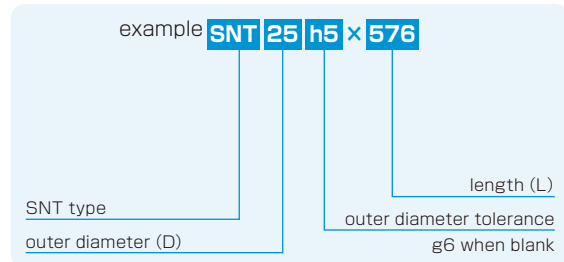

part number	outer diameter		inner diameter	length		mass
	D	tolerance		L		
	mm	g6 μm	d mm	mm	mm	Kg/m
<b>SNT 6</b>	6	-4/-12	2	100	400	0.20
<b>SNT 8</b>	8	-5	3	200	600	0.34
<b>SNT 10</b>	10	-14	4	200	1000	0.52
<b>SNT 12</b>	12	-6	5	200	1500	0.73
<b>SNT 13</b>	13	-6	6	200	1500	0.82
<b>SNT 16</b>	16	-17	8	300	2500	1.18
<b>SNT 20</b>	20	-7	10	300	4000	1.85
<b>SNT 25</b>	25	-20	15	300	4000	2.46
<b>SNT 30</b>	30	-7	16	300	4500	3.97
<b>SNT 35</b>	35	-9	19	400	4500	5.32
<b>SNT 40</b>	40	-25	20	400	4500	7.39
<b>SNT 50</b>	50	-10	26	500	4500	11.3
<b>SNT 60</b>	60	-29	32	600	4500	15.9
<b>SNT 80</b>	80	-12/-34	48	800	4500	25.3
<b>SNT 100</b>	100	-12/-34	60	1000	4500	39.5

material: high-carbon chromium bearing steel (SUJ2)  
hardness: 60HRC (HV697) or more  
Tolerances other than g6 are available upon request.

# NB CENTER-LINED TAPPED SHAFT

A larger diameter shaft can overcome problems in maintaining precision functionality when a high or unbalanced load is applied. A combination of the center-lined tapped shaft together with the SA type support rail is ideal in such cases. (see pages F-18,19) The center-lined tapped shaft is standardized to simplify shaft selection.

## part number structure

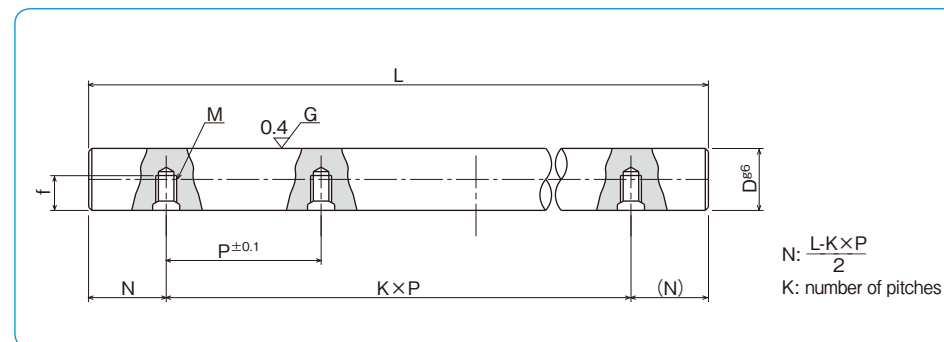
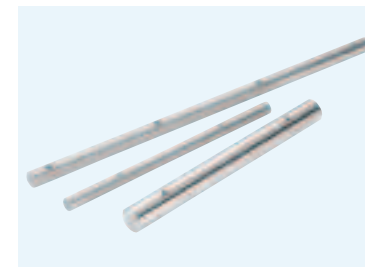
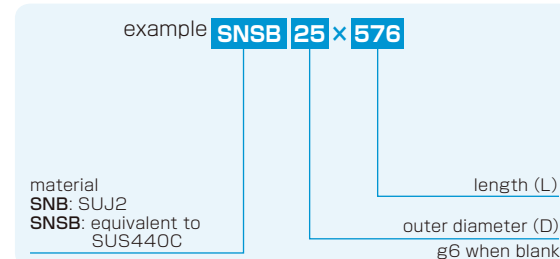

## NB Center-Lined Tapped Shaft

part number	outer diameter	tolerance	pitch	screw	tap	maximum
	D	g6*	P	size	depth	length
	mm	μm	mm	M	f	L <sub>max</sub>
<b>SNB10</b>	10	-5/-14	100	M4	4.5	1,500
<b>SNB12</b>	12	-6	100	M4	5.5	1,800
<b>SNB13</b>	13	-17	100	M4	6	2,000
<b>SNB16</b>	16	-6	150	M5	7	2,000
<b>SNB20</b>	20	-7	150	M6	9	3,000
<b>SNB25</b>	25	-20	200	M6	12	4,000
<b>SNB30</b>	30	-20	200	M8	15	4,500
<b>SNB35</b>	35	-9	200	M8	15	5,000
<b>SNB40</b>	40	-25	300	M8	18	6,000
<b>SNB50</b>	50	-25	300	M10	22	6,000

material: high-carbon chromium bearing steel (SUJ2)  
hardness: 60HRC (HV697) or more  
\*g6 is a standard tolerance of the outer diameter.

## NB Center-Lined Tapped Stainless Steel Shaft

part number	outer diameter	tolerance	pitch	screw	tap	maximum
	D	g6*	P	size	depth	length
	mm	μm	mm	M	f	L <sub>max</sub>
<b>SNSB16</b>	16	-6/-17	150	M5	7	2,000
<b>SNSB20</b>	20	-7	150	M6	9	3,000
<b>SNSB25</b>	25	-20	200	M6	12	4,000
<b>SNSB30</b>	30	-20	200	M8	15	4,500
<b>SNSB35</b>	35	-9	200	M8	15	5,000
<b>SNSB40</b>	40	-25	300	M8	18	6,000
<b>SNSB50</b>	50	-25	300	M10	22	6,000

material: martensite stainless steel (equivalent to SUS440C)  
hardness: 56HRC (HV613) or more  
\*g6 is a standard tolerance of the outer diameter.

# SNW TYPE

– NB Inch Shaft –

## part number structure

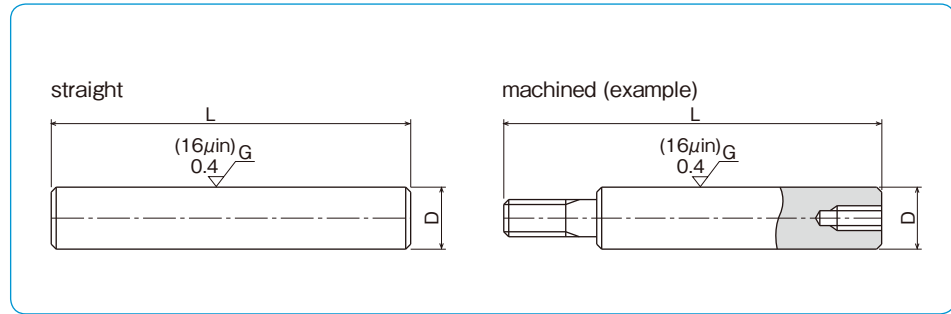
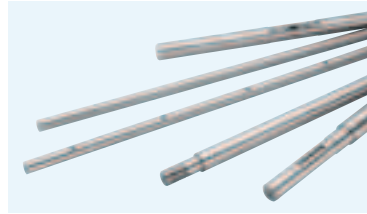
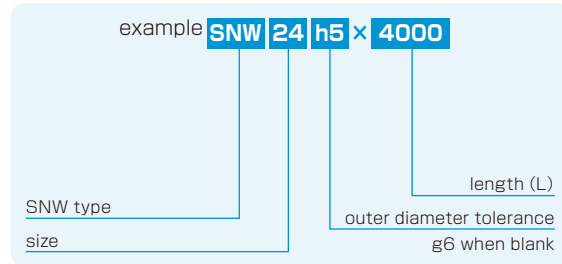

part number	outer diameter		length L	mass
	D inch mm	tolerance g6 inch/µm		
SNW 4	1/4 6.350	-.0002 -.0006	3.94 ← → 39.37 100 ← → 1000	0.014 0.25
SNW 6	3/8 9.525	-5 -14	7.84 ← → 59.06 200 ← → 1500	0.031 0.56
SNW 8	1/2 12.700	-.0002 -.0007	7.84 ← → 118.11 200 ← → 3000	0.056 0.99
SNW10	5/8 15.875	-6 -17	7.84 ← → 157.48 200 ← → 4000	0.086 1.55
SNW12	3/4 19.050	-.0003 -.0008	11.81 ← → 157.48 300 ← → 4000	0.125 2.24
SNW16	1 25.400	-7 -20	11.81 ← → 157.48 300 ← → 4000	0.222 3.98
SNW20	1-1/4 31.750	-.0004 -.0010	11.81 ← → 157.48 300 ← → 4000	0.348 6.22
SNW24	1-1/2 38.100	-9 -25	15.75 ← → 157.48 400 ← → 4000	0.500 8.95
SNW32	2 50.800	-.0004 -.0011	19.69 ← → 157.48 500 ← → 4000	0.890 15.91
SNW40	2-1/2 63.500	-10 -29	23.62 ← → 157.48 600 ← → 4000	1.391 25.00
SNW48	3 76.200	-9 -29	23.62 ← → 157.48 600 ← → 4000	2.003 37.92
SNW64	4 101.600	-.0005/-0013 -12/-34	39.37 ← → 157.48 1000 ← → 4000	3.560 64.02

material: high-carbon chromium bearing steel (SUJ2)  
hardness: 60HRC (HV697) or more  
Tolerances other than g6 are available upon request.

1kg≐2.205lbs

# SNWS TYPE

– NB Inch Stainless Steel Shaft –

## part number structure

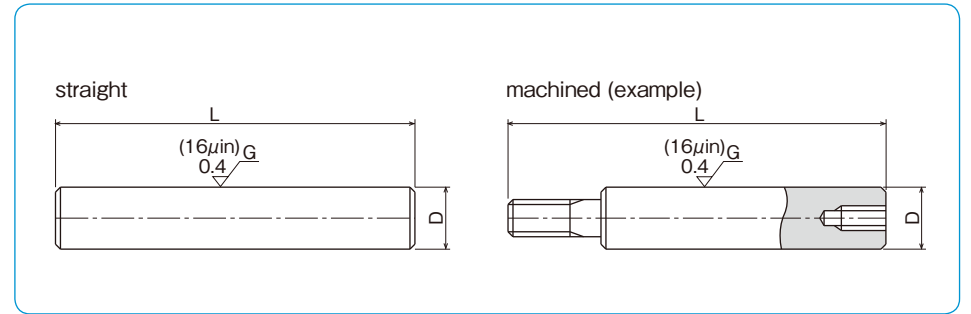
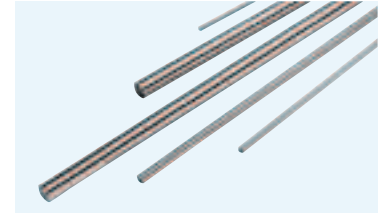
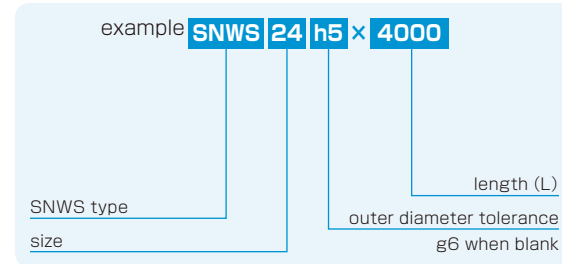

part number	outer diameter		length L	mass
	D inch mm	tolerance g6 inch/µm		
SNWS 4	1/4 6.350	-.0002 -.0006	3.94 ← → 23.62 100 ← → 600	0.014 0.25
SNWS 6	3/8 9.525	-5 -14	7.84 ← → 39.37 200 ← → 1000	0.031 0.55
SNWS 8	1/2 12.700	-.0002 -.0007	7.84 ← → 98.43 200 ← → 2500	0.056 0.98
SNWS10	5/8 15.875	-6 -17	7.84 ← → 118.11 200 ← → 3000	0.086 1.54
SNWS12	3/4 19.050	-.0003 -.0008	11.81 ← → 157.48 300 ← → 4000	0.125 2.22
SNWS16	1 25.400	-7 -20	11.81 ← → 157.48 300 ← → 4000	0.222 3.95
SNWS20	1-1/4 31.750	-.0004 -.0010	11.81 ← → 157.48 300 ← → 4000	0.420 6.16
SNWS24	1-1/2 38.100	-9 -25	15.75 ← → 157.48 400 ← → 4000	0.500 8.88
SNWS32	2 50.800	-.0004/-0011 -10/-29	19.69 ← → 157.48 500 ← → 4000	0.890 15.78

material: martensite stainless steel (equivalent to SUS440C)  
hardness: 56HRC (HV613) or more  
Tolerances other than g6 are available upon request.

1kg≐2.205lbs

# SNW-PD

– NB Inch Pre-Drilled Shaft –

## part number structure

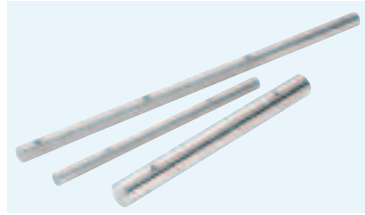
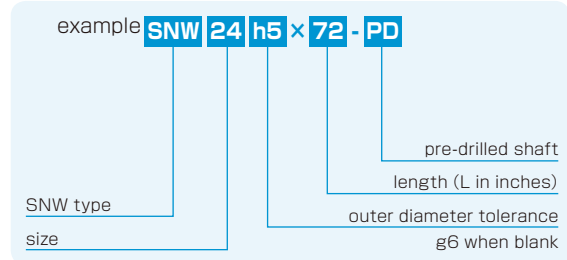

# SNWS-PD

– NB Inch Pre-Drilled Stainless Steel Shaft –

## part number structure

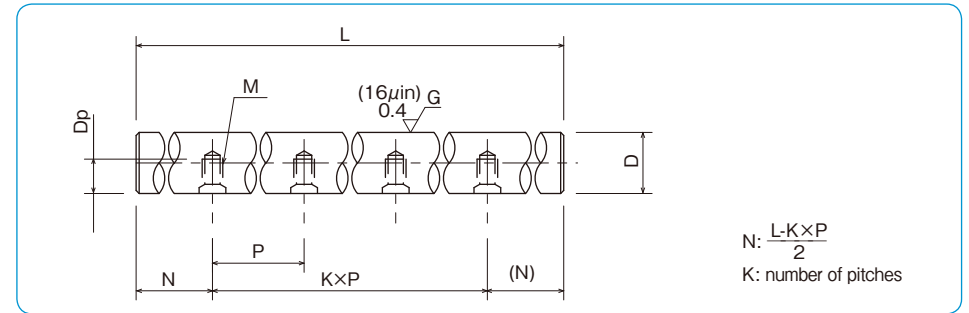
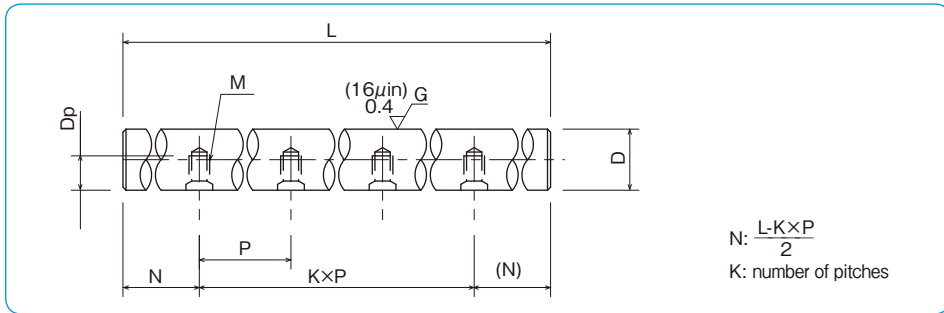
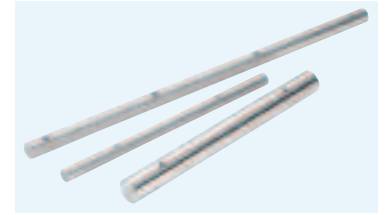
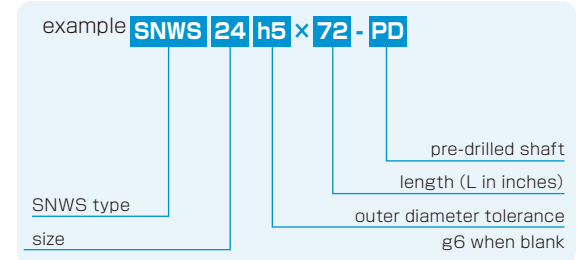

part number	outer diameter		pitch P inch/mm	bolt size M	tapped hole depth Dp inch/mm	maximum length L inch/mm
	D inch mm	tolerance g6* inch/ $\mu$ m				
<b>SNW 8-PD</b>	1/2 12.700	-.0002 -.0007	4 101.6	# 6-32	0.280 7.1	72 1,828.8
<b>SNW 10-PD</b>	5/8 15.875	-6 -17			0.350 8.9	
<b>SNW 12-PD</b>	3/4 19.050	-.0003 -.0008	6 152.4	# 10-32	0.400 10.2	
<b>SNW 16-PD</b>	1 25.400	-7 -20			0.500 12.7	
<b>SNW 20-PD</b>	1-1/4 31.750	-.0004 -.0010	8 203.2	5/16-18	0.650 16.5	
<b>SNW 24-PD</b>	1-1/2 38.100	-9 -25			0.700 17.8	
<b>SNW 32-PD</b>	2 50.800	-.0004/-0.0011 -10/-29		3/8-16	0.850 21.6	

material: high-carbon chromium bearing steel (SUJ2)  
hardness: 60HRC (HV697) or more  
Tolerances other than \*g6 are available upon request.  
Longer lengths are also available.

1kg $\approx$ 2.205lbs

part number	outer diameter		pitch P inch/mm	bolt size M	tapped hole depth Dp inch/mm	maximum length L inch/mm
	D inch mm	tolerance g6* inch/ $\mu$ m				
<b>SNWS 12-PD</b>	3/4 19.050	-.0003 -.0008	6 152.4	#10-32	0.400 10.2	72 1,828.8
<b>SNWS 16-PD</b>	1 25.400	-7 -20			0.500 12.7	
<b>SNWS 20-PD</b>	1-1/4 31.750	-.0004 -.0010			0.650 16.5	
<b>SNWS 24-PD</b>	1-1/2 38.100	-9 -25	8 203.2	3/8-16	0.700 17.8	
<b>SNWS 32-PD</b>	2 50.800	-.0004/-0.0011 -10/-29			0.850 21.6	

material: martensite stainless steel (equivalent to SUS440C)  
hardness: 56HRC (HV613) or more  
Tolerances other than \*g6 are available upon request.  
Longer lengths are also available.

SHAFT SUPPORTER AND SHAFT SUPPORT RAIL

These components save design/assembling time and ease shaft installation.

SH·SH-A·WH-A type

These are most commonly used compact shaft supporters. SH type is made of cast iron and SH-A/WH-A type is made of aluminum alloy.

SHF·SHF-FC type

These are flanged type shaft supporters for a compact design. SHF is made of aluminum alloy and SHF-FC (shaft diameter 35 and over) is made of cast iron.

SA·WA·LWA type (shaft support rail)

These support rails support shafts from below to avoid shaft deflection for a long-stroke/high load application. This type is made of aluminum alloy.

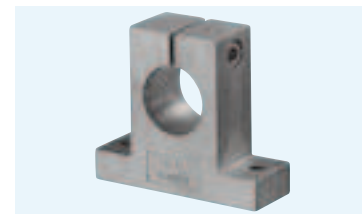
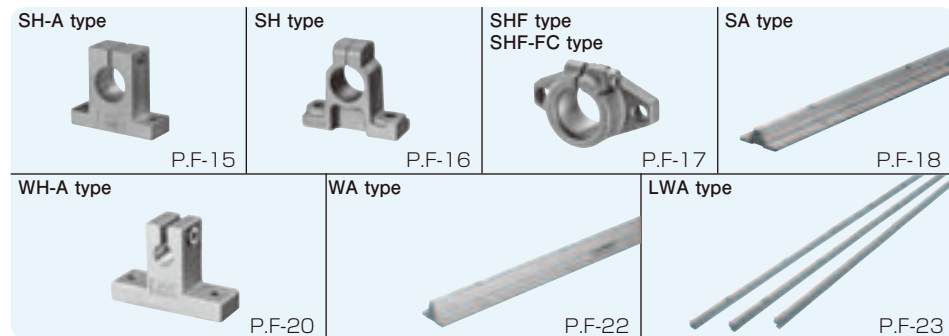

SH-A TYPE

– Shaft Supporter –

part number structure

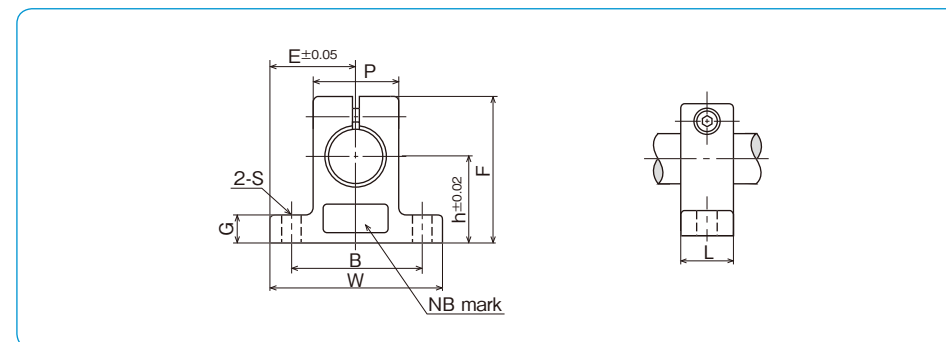
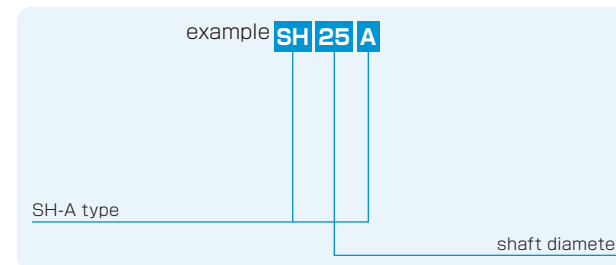

ACCURACY

The accuracy of the SA support rails are measured as shown in Figure F-1.

Figure F-1 Measurement Method

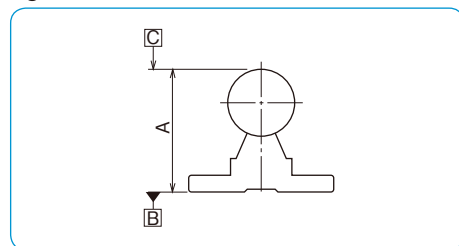
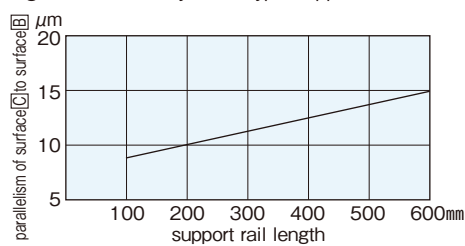

Figure F-2 Accuracy of SA type Support Rail



part number	shaft diameter mm	major dimensions									tightening screw		mass g
		h mm	E mm	W mm	L mm	F mm	G mm	P mm	B mm	S mm	size	recommended torque N·m	
SH 8A	8	20	21	42	14	32.8	6	18	32	5.5 (M5)	M4	2	24
SH10A	10	20	21	42	14	32.8	6	18	32	5.5 (M5)	M4	2	24
SH12A	12	23	21	42	14	37.5	6	20	32	5.5 (M5)	M4	2	30
SH13A	13	23	21	42	14	37.5	6	20	32	5.5 (M5)	M4	2	30
SH16A	16	27	24	48	16	44	8	25	38	5.5 (M5)	M4	2	40
SH20A	20	31	30	60	20	51	10	30	45	6.6 (M6)	M5	3	70
SH25A	25	35	35	70	24	60	12	38	56	6.6 (M6)	M6	5.5	130
SH30A	30	42	42	84	28	70	12	44	64	9 (M8)	M6	5.5	180
SH35A	35	50	49	98	32	82	15	50	74	11 (M10)	M8	13.5	270
SH40A	40	60	57	114	36	96	15	60	90	11 (M10)	M8	13.5	420
SH50A	50	70	63	126	40	120	18	74	100	14 (M12)	M12	29	750
SH60A	60	80	74	148	45	136	18	90	120	14 (M12)	M12	29	1,100

# SH TYPE

– Shaft Supporter –



## part number structure

example **SH 25**

SH type

shaft diameter

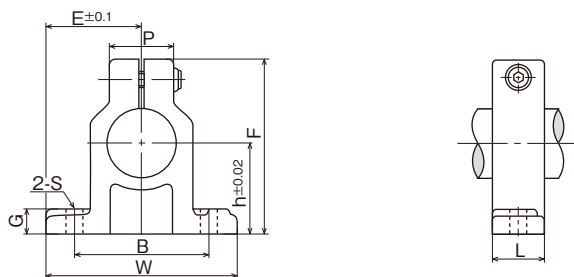

part number	shaft diameter mm	major dimensions									tightening screw size	recommended torque N · m	mass g
		h mm	E mm	W mm	L mm	F mm	G mm	P mm	B mm	S mm			
SH10	10	20	22	44	15	35	7	19	32	4.5 (M4)	M4	2	80
SH13	13	23	25	50	17	40	8	17	32	7 (M5)	M4	2	120
SH16	16	27	27.5	55	17	45	10	16	38	7 (M5)	M4	2	120
SH20	20	31	32.5	65	20	53	12	22	45	8 (M6)	M5	3	190
SH25	25	35	38	76	24	61	12	24	56	8 (M6)	M6	5.5	300
SH30	30	42	42.5	85	28	73	15	28	64	10 (M8)	M6	5.5	490
SH35	35	50	50	100	32	87	15	34	74	12 (M10)	M8	13.5	690
SH40	40	60	60	120	36	104	18	38	90	12 (M10)	M10	29	1,200
SH50	50	70	70	140	40	122	20	48	100	14 (M12)	M12	29	1,700
SH60	60	80	82.5	165	45	140	23	58	120	14 (M12)	M12	29	2,500

# SHF TYPE

– Shaft Supporter Flange Type –



## part number structure

example **SHF 35 FC**

SHF type

shaft diameter

blank: aluminum alloy  
FC: cast iron

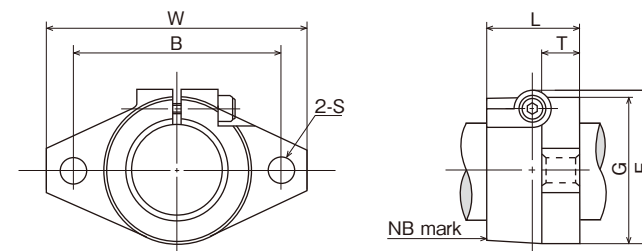

part number		shaft diameter mm	major dimensions						tightening screw size	recommended torque N · m	mass g		
aluminum alloy	cast iron		W mm	L mm	T mm	F mm	G mm	B mm			S mm	aluminum alloy	cast iron
SHF10	–	10	43	10	5	24	20	32	5.5 (M5)	M4	2	13	–
SHF12	–	12	47	13	7	28	25	36	5.5 (M5)	M4	2	20	–
SHF13	–	13	47	13	7	28	25	36	5.5 (M5)	M4	2	20	–
SHF16	–	16	50	16	8	31	28	40	5.5 (M5)	M4	2	27	–
SHF20	–	20	60	20	8	37	34	48	7 (M6)	M5	3	40	–
SHF25	–	25	70	25	10	42	40	56	7 (M6)	M5	3	60	–
SHF30	–	30	80	30	12	50	46	64	9 (M8)	M6	5.5	110	–
SHF35	SHF35FC	35	92	35	14	58	50	72	12 (M10)	M8	13.5	140	380
SHF40	SHF40FC	40	102	40	16	67	56	80	12 (M10)	M10	29	205	510
SHF50	SHF50FC	50	122	50	19	83	70	96	14 (M12)	M12	29	360	890
SHF60	SHF60FC	60	140	60	23	95	82	112	14 (M12)	M12	29	530	1,500

# SA TYPE

– Shaft Support Rail –

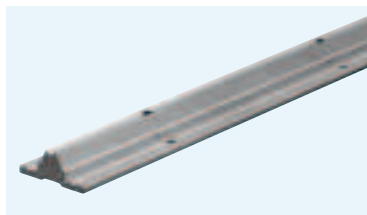

## part number structure

example SA 25-500

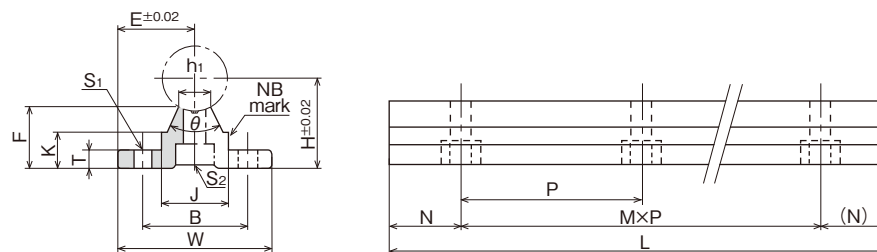
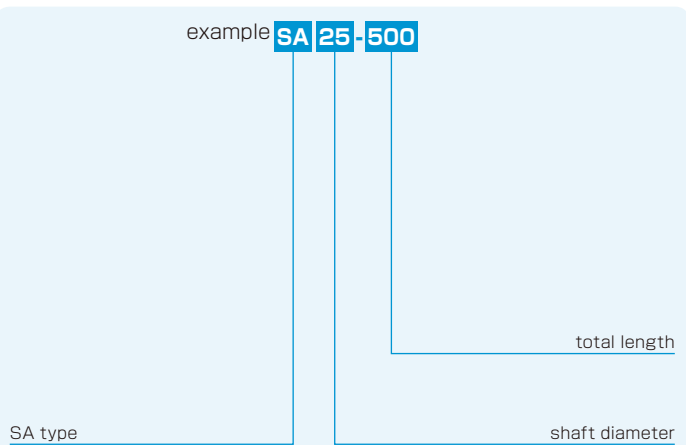

※ Mounting screws for the SN(S)B center-lined tapped shaft are included.

part number	shaft diameter mm	major dimensions												mass g				
		H	E	W	L	F	T	K	J	h <sub>1</sub>	θ	B	N		M×P	S <sub>1</sub>	S <sub>2</sub>	
SA10-200	10	18	16	32	200	13.5	4	8.9	12.4	4.7	80°	22	50	1×100	4.5	M4	110	
SA10-300					300								50	2×100				160
SA10-400					400								50	3×100				220
SA10-500					500								50	4×100				270
SA10-600					600								50	5×100				330
SA13-200	13	21	17	34	200	15	4.5	9.8	15	6	80°	25	50	1×100	4.5	M4	140	
SA13-300					300								50	2×100				210
SA13-400					400								50	3×100				280
SA13-500					500								50	4×100				350
SA13-600					600								50	5×100				420
SA16-200	16	25	20	40	200	17.8	5	11.7	18.5	8	80°	30	25	1×150	5.5	M5	200	
SA16-300					300								75	1×150				300
SA16-400					400								50	2×150				400
SA16-500					500								25	3×150				500
SA16-600					600								75	3×150				600
SA20-200	20	27	22.5	45	200	17.7	5	10	19	8	50°	30	25	1×150	5.5	M6	200	
SA20-300					300								75	1×150				300
SA20-400					400								50	2×150				400
SA20-500					500								25	3×150				510
SA20-600					600								75	3×150				610
SA25-200	25	33	27.5	55	200	21	6	12	21.5	8	50°	35	25	1×150	6.5	M6	290	
SA25-300					300								50	1×200				430
SA25-400					400								100	1×200				580
SA25-500					500								50	2×200				730
SA25-600					600								100	2×200				880

part number	shaft diameter mm	major dimensions												mass g				
		H	E	W	L	F	T	K	J	h <sub>1</sub>	θ	B	N		M×P	S <sub>1</sub>	S <sub>2</sub>	
SA30-200	30	37	30	60	200	22.8	7	13	26.5	10.3	50°	40	25	1×150	6.5	M8	360	
SA30-300					300								50	1×200				550
SA30-400					400								100	1×200				730
SA30-500					500								50	2×200				920
SA30-600					600								100	2×200				1,100
SA35-200	35	43	32.5	65	200	26.5	8	15.5	28	13	50°	45	25	1×150	9	M8	460	
SA35-300					300								50	1×200				700
SA35-400					400								100	1×200				950
SA35-500					500								50	2×200				1,190
SA35-600					600								100	2×200				1,420
SA40-200	40	48	37.5	75	200	29.4	9	17	38	16	50°	55	25	1×150	9	M8	630	
SA40-300					300								75	1×150				960
SA40-400					400								50	1×300				1,290
SA40-500					500								100	1×300				1,610
SA40-600					600								150	1×300				1,950
SA50-200	50	62	47.5	95	200	38.8	11	21	45	20	50°	70	25	1×150	11	M10	1,000	
SA50-300					300								75	1×150				1,500
SA50-400					400								50	1×300				2,000
SA50-500					500								100	1×300				2,500
SA50-600					600								150	1×300				3,000

# WH-A TYPE

– Shaft Supporter –  
(Inch Standard)

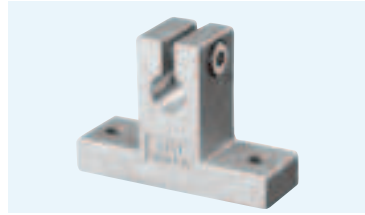

### part number structure

example **WH** | **24** | **A**

WH-A type

size

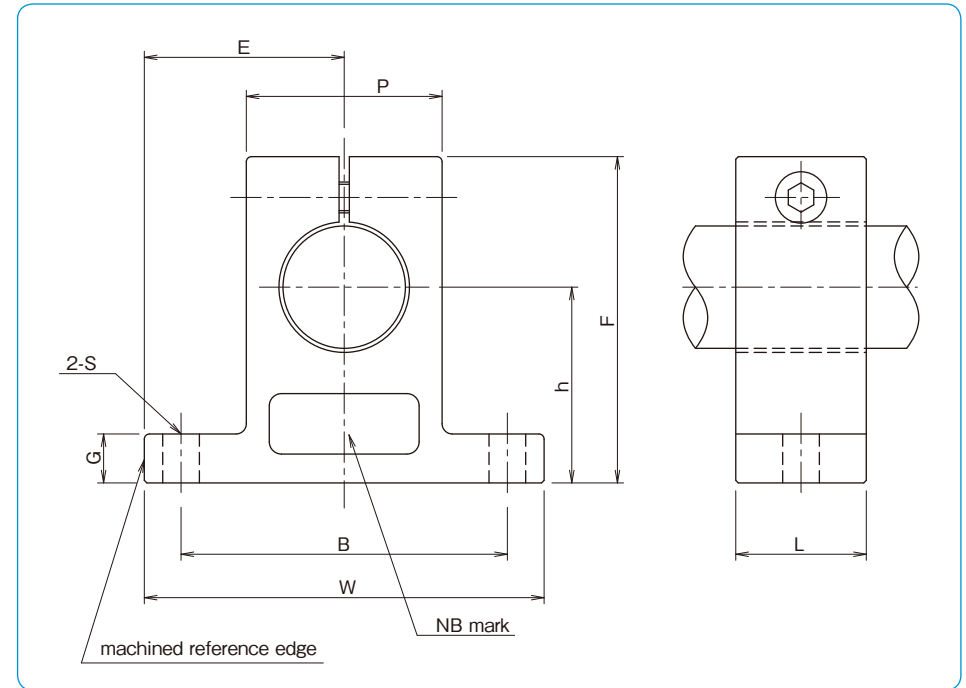

part number	shaft diameter inch	major dimensions				
		h ±.001 inch	E ±.005 inch	W inch	L inch	F inch
<b>WH 4A</b>	.2500	.6875	.7500	1.500	.500	1.063
<b>WH 6A</b>	.3750	.7500	.8125	1.625	.563	1.187
<b>WH 8A</b>	.5000	1.0000	1.0000	2.000	.625	1.625
<b>WH 10A</b>	.6250	1.0000	1.2500	2.500	.688	1.750
<b>WH 12A</b>	.7500	1.2500	1.2500	2.500	.750	2.063
<b>WH 16A</b>	1.0000	1.5000	1.5315	3.063	1.000	2.500
<b>WH 20A</b>	1.2500	1.7500	1.8750	3.750	1.125	3.000
<b>WH 24A</b>	1.5000	2.0000	2.1875	4.375	1.250	3.437
<b>WH 32A</b>	2.0000	2.5000	2.7500	5.500	1.500	4.375

major dimensions					mass lbs	part number
G inch	P inch	B ±.01 inch	S inch	bolt# inch		
.250	.500	1.125	.156	# 6	.033	<b>WH 4A</b>
.250	.688	1.250	.156	# 6	.044	<b>WH 6A</b>
.250	.875	1.500	.188	# 8	.075	<b>WH 8A</b>
.313	1.000	1.875	.218	#10	.106	<b>WH 10A</b>
.313	1.250	2.000	.218	#10	.156	<b>WH 12A</b>
.375	1.500	2.500	.281	1/4	.294	<b>WH 16A</b>
.438	2.000	3.000	.346	5/16	.531	<b>WH 20A</b>
.500	2.250	3.500	.346	5/16	.725	<b>WH 24A</b>
.625	3.000	4.500	.406	3/8	1.400	<b>WH 32A</b>

1kg≐2.205lbs  
1lb≐0.454kg

# WA TYPE

– Shaft Support Rail –  
(Inch Standard)

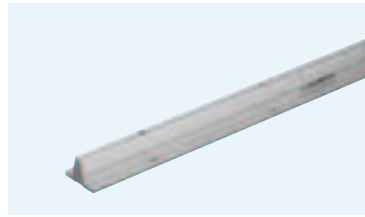

## part number structure

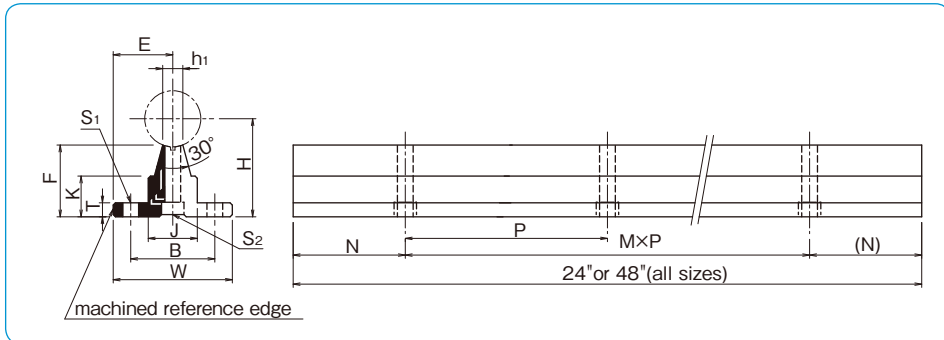
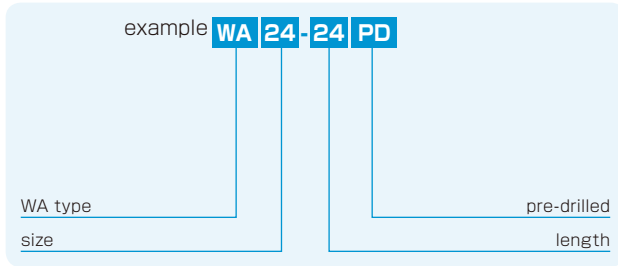

part number	shaft diameter inch	major dimensions								mounting dimensions						mass lbs		
		H ±.001 inch	E ±.005 inch	W inch	F inch	T inch	K inch	J inch	h <sub>1</sub> inch	B ±.01 inch	N inch	M×P inch	S <sub>1</sub> hole inch	S <sub>2</sub> hole inch	S <sub>1</sub> bolt#		S <sub>2</sub> bolt#	
WA 8-	24PD	.5000	1.125	.7500	1.500	.903	.188	.466	.500	.255	1.000	2	5×4	.169	#6	.169	#6	1.326
	48PD												11×4					2.652
WA10-	24PD	.6250	1.125	.8125	1.625	.841	.250	.423	.500	.276	1.125	2	5×4	.193	#8	.193	#8	1.488
	48PD												11×4					2.976
WA12-	24PD	.7500	1.500	.8750	1.750	1.158	.250	.592	.625	.322	1.250	3	3×6	.221	#10	.221	#10	2.100
	48PD												7×6					4.200
WA16-	24PD	1.0000	1.750	1.0625	2.125	1.280	.250	.727	.875	.359	1.500	3	3×6	.281	1/4	.281	1/4	2.776
	48PD												7×6					5.552
WA20-	24PD	1.2500	2.125	1.2500	2.500	1.537	.313	.799	1.100	.437	1.875	3	3×6	.343	5/16	.343	5/16	4.060
	48PD												7×6					8.120
WA24-	24PD	1.5000	2.500	1.5000	3.000	1.798	.375	.922	1.375	.558	2.250	4	2×8	.343	5/16	.406	3/8	5.840
	48PD												5×8					11.680
WA32-	24PD	2.0000	3.250	1.8750	3.750	2.322	.500	1.450	1.500	.800	2.750	4	2×8	.406	3/8	.531	1/2	9.500
	48PD												5×8					19.000

All sizes are also available without pre-drilled mounting holes.  
Complete shaft-rail assemblies are also available as well as custom drilling and lengths.  
Please send drawings with customer specifications.

1kg≅2.205lbs  
1lb≅0.454kg

# LWA TYPE

– Low Shaft Support Rail –  
(Inch Standard)

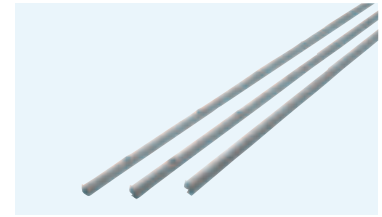

## part number structure

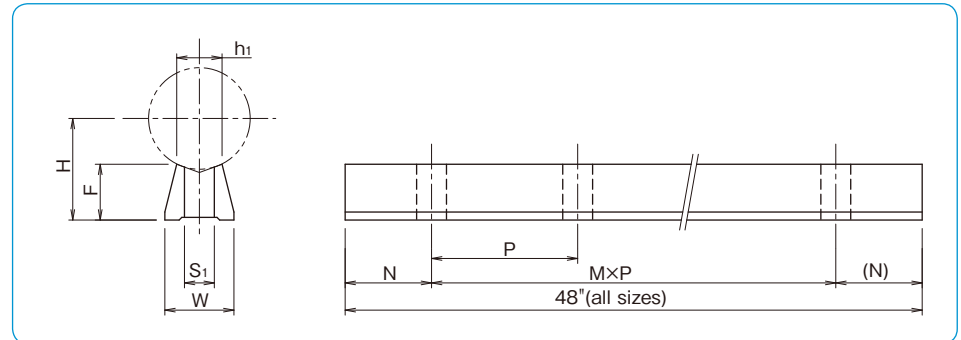
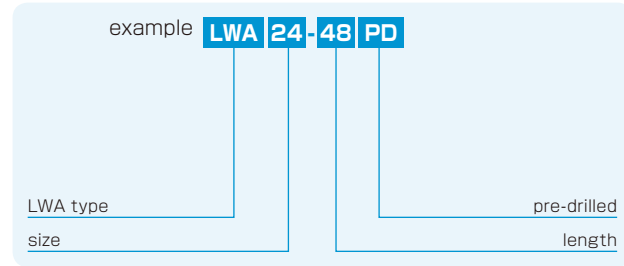

part number	shaft diameter inch	major dimensions			major dimensions				mass lb
		H ±.002 inch	W inch	F inch	N inch	M×P inch	h <sub>1</sub> inch	S <sub>1</sub> inch	
LWA 8-48 PD	.5000	.5625	.37	.341	2	11×4	.216	.169	0.11
LWA 10-48 PD	.6250	.6875	.45	.405	2	11×4	.269	.193	0.17
LWA 12-48 PD	.7500	.7500	.51	.409	3	7×6	.317	.224	0.20
LWA 16-48 PD	1.0000	1.0000	.69	.545	3	7×6	.422	.281	0.35
LWA 20-48 PD	1.2500	1.1875	.78	.617	3	7×6	.523	.343	0.44
LWA 24-48 PD	1.5000	1.3750	.96	.691	4	5×8	.623	.406	0.58
LWA 32-48 PD	2.0000	1.7500	1.18	.836	4	5×8	.824	.531	0.89

1kg≅2.205lbs  
1lb≅0.454kg



## RANGE AND SPECIFICATIONS OF MACHINING

NB does shaft-machining based on the customer requirements.

### Range Of Machining

maximum diameter — 650mm  
 maximum length — 6000mm  
 surface roughness — 0.4Ra or less

straightness — customer specification  
 concentricity — customer specification  
 squareness — customer specification  
 cylindricity — customer specification

### Internal Surface Grinding

The straight/tapered portion of the inner spindle can be ground.

### gun drill Machining

hole diameter	maximum length of hole	
	non through hole	through hole
φ2 ~ 2.5mm	200	400
φ3 ~ 3.5mm	300	600
φ4 ~ 8mm	500	1000
φ9 ~ 10mm	750	1500
φ10 ~ 32mm	850	1700
φ30 ~ 80mm	2000	4000

### Thread Grinding

Triangular and trapezoidal threading can be handled.

### Compatible Parts

Special nuts compatible with a given shaft can be machined. The inner surface and outer diameter of the tapered portion can be ground.

### Material and Heat Treatment

NB's non-standard material and non-standard shaped parts can be heat treated. Please specify the heat treatment method, hardness, and heat-treated area.

### Gun Drill Machining

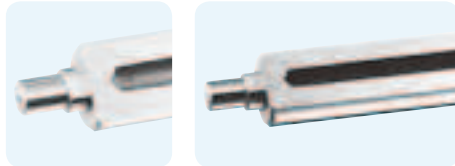

## EXAMPLES OF MACHINING

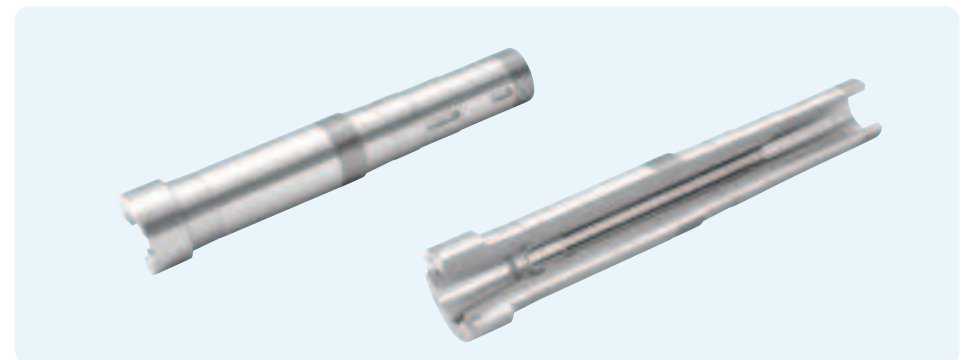
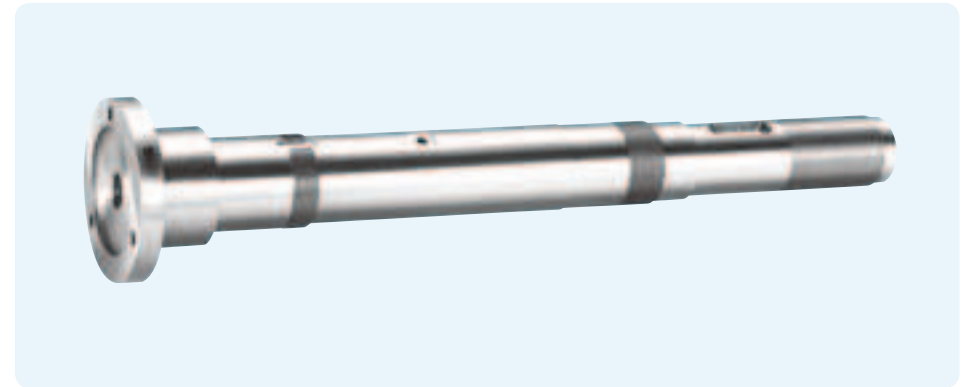
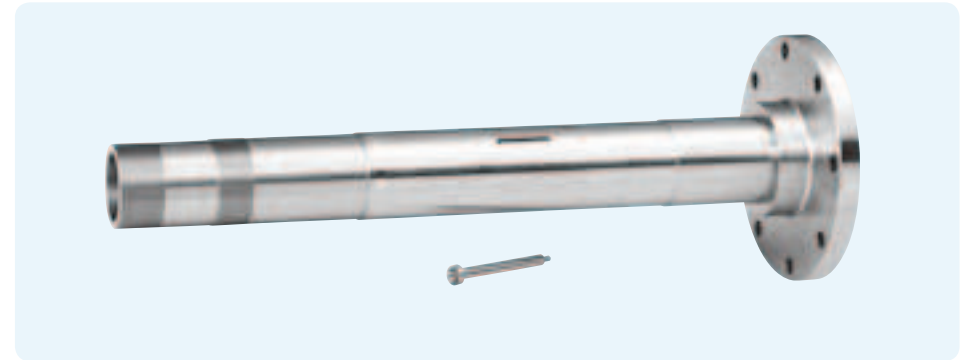

## EXAMPLES OF MACHINING

### Main Spindle



EXAMPLES OF MACHINING

Roll Shaft

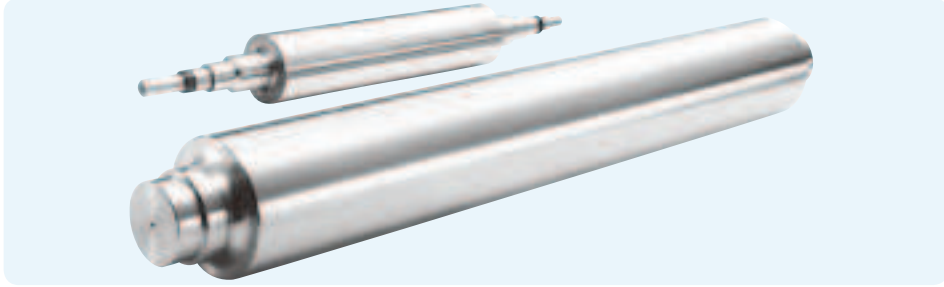

Quill Shaft

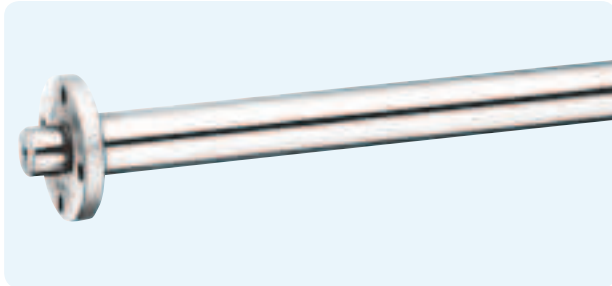
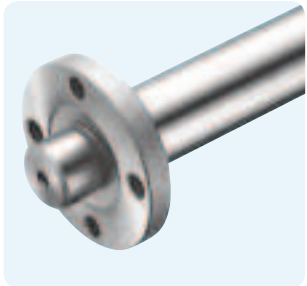
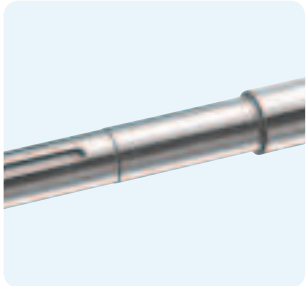
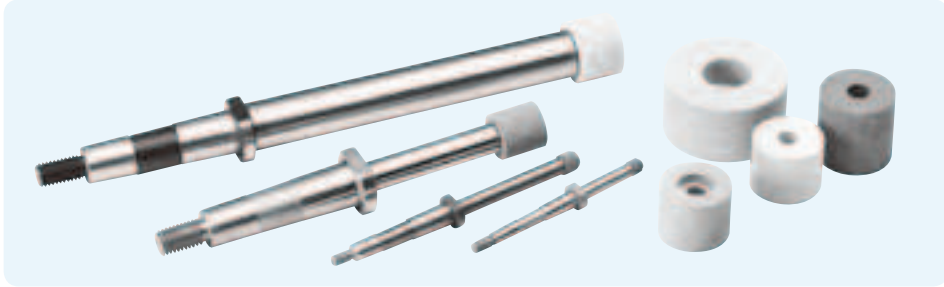

EXAMPLES OF MACHINING

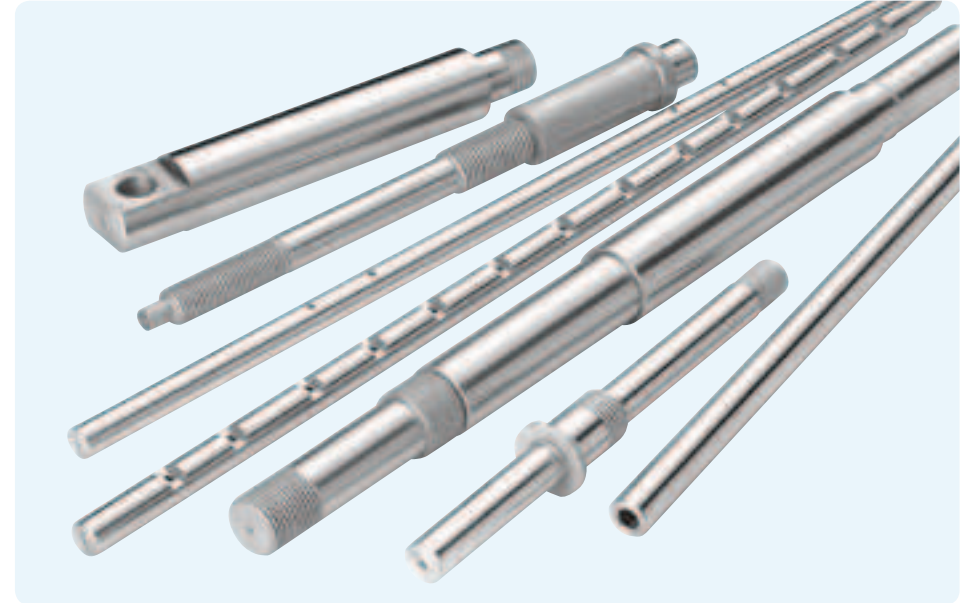
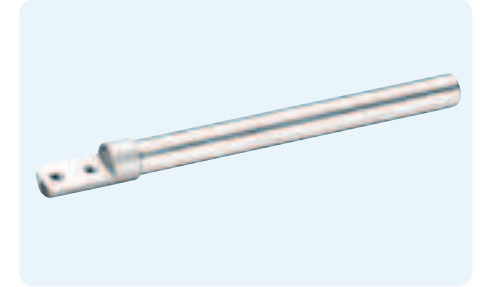
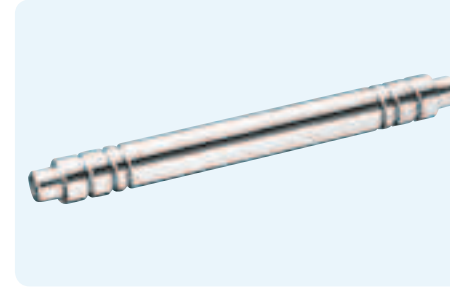
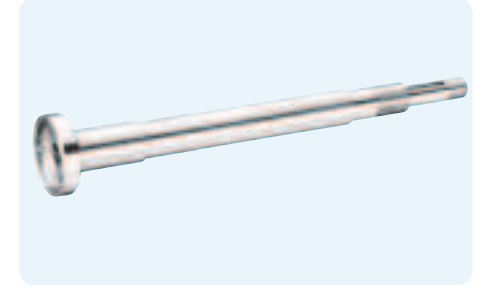
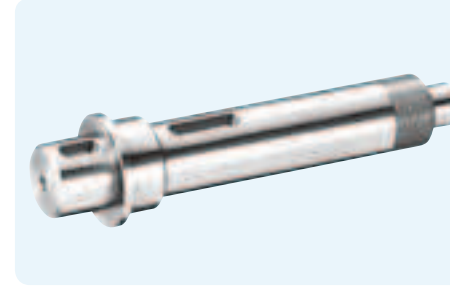

Please visit at NB Website for more examples of machining.